



Do More with Your Data and Your Day

Autodesk PLM

Kimberley Hendrix
Manager of Data Management

Michael Pares
Manager of Enterprise Services

Ben Banford
Specialized Solutions Executive



A COMMONLY-OWNED COALITION OF BRANDS



Agenda



Organize your data



Optimize your processes



Centralize your stakeholders



Questions

Introductions

Kimberley Hendrix
Manager of Data Management
Tulsa, Ok



Michael Pares
Manager of Enterprise Services
Fayetteville, AR



Ben Banford
Specialized Solutions Executive
Salt Lake City, UT





A COALITION OF BRANDS

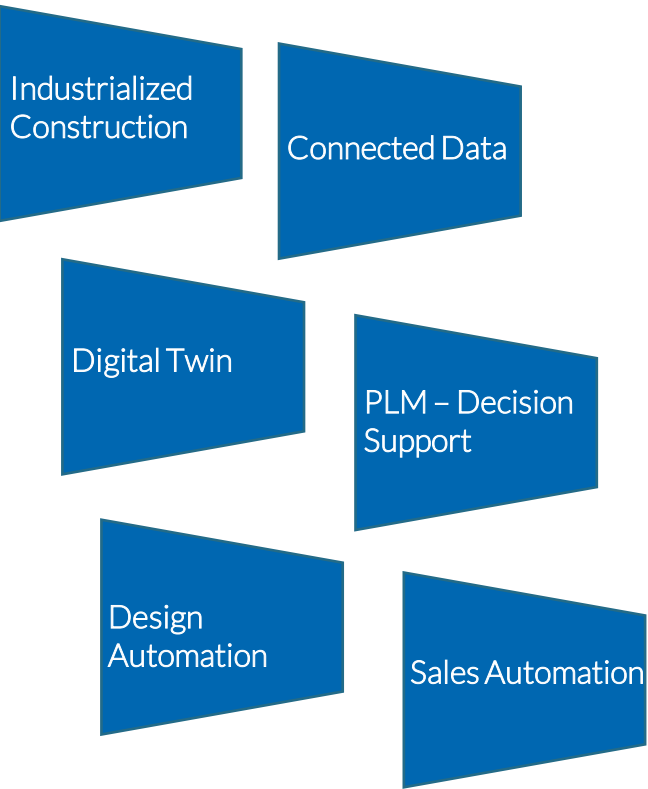

Business Outcomes through Data Integration

- Autodesk Platinum Partner
- Deep Industry Experience
- Diverse Technical Delivery
- Project Management Office
- Focused on Data Integration
 - IP Developed for Data Migration
 - IP Developed for Automation



PLM

Cloud

Agility

Communication

Remote

Data

Connected

IoT

Investment

Aligned

Competitive

Essential

Innovation

SaaS

Integration

Strategy

Empowerment

Future

Digital

Mobile

Technology

Change

Process

Smart

Collaboration

Supply chain

Everywhere

Virtual

Algorithms

Analytics

Development

New

Why manufacturers invest in PLM

Business outcomes you can achieve

Faster time to market



Improve collaboration

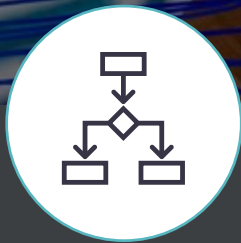

Increase product development agility



Improve supply chain agility



Reduce time spent on low value tasks

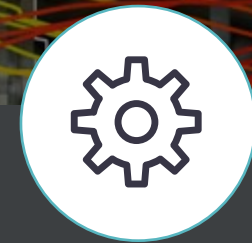

Reduce defects and non-conformities

Autodesk PLM

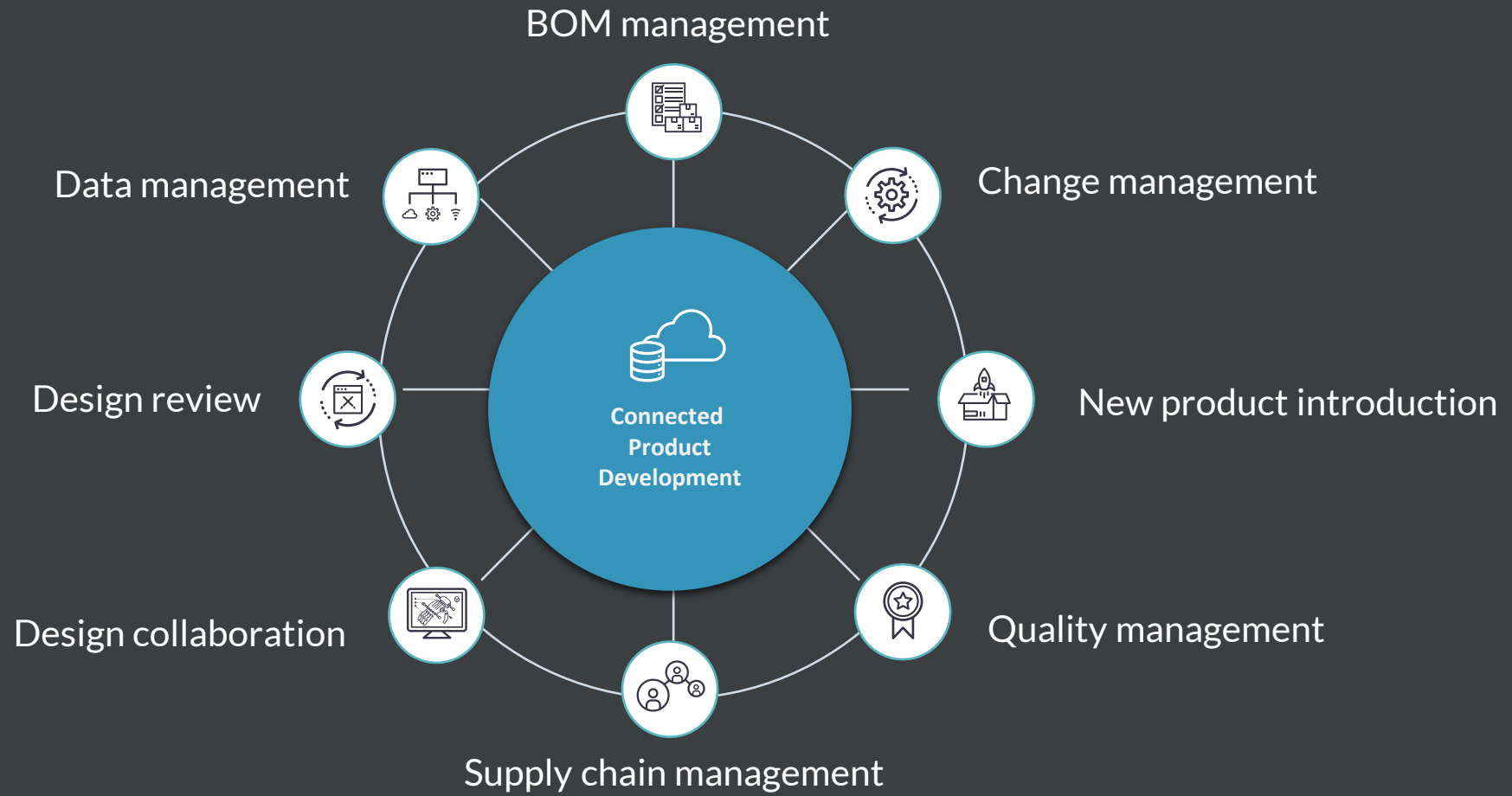

Organize Your Data

Some Challenges we have seen with Data

- Systems aren't communicating / data silos
- Software isn't easy to use / lack of adoption
- Teams are dispersed / aren't communicating
- Data isn't kept up to date
- Other (email, dropbox, onedrive, etc.)

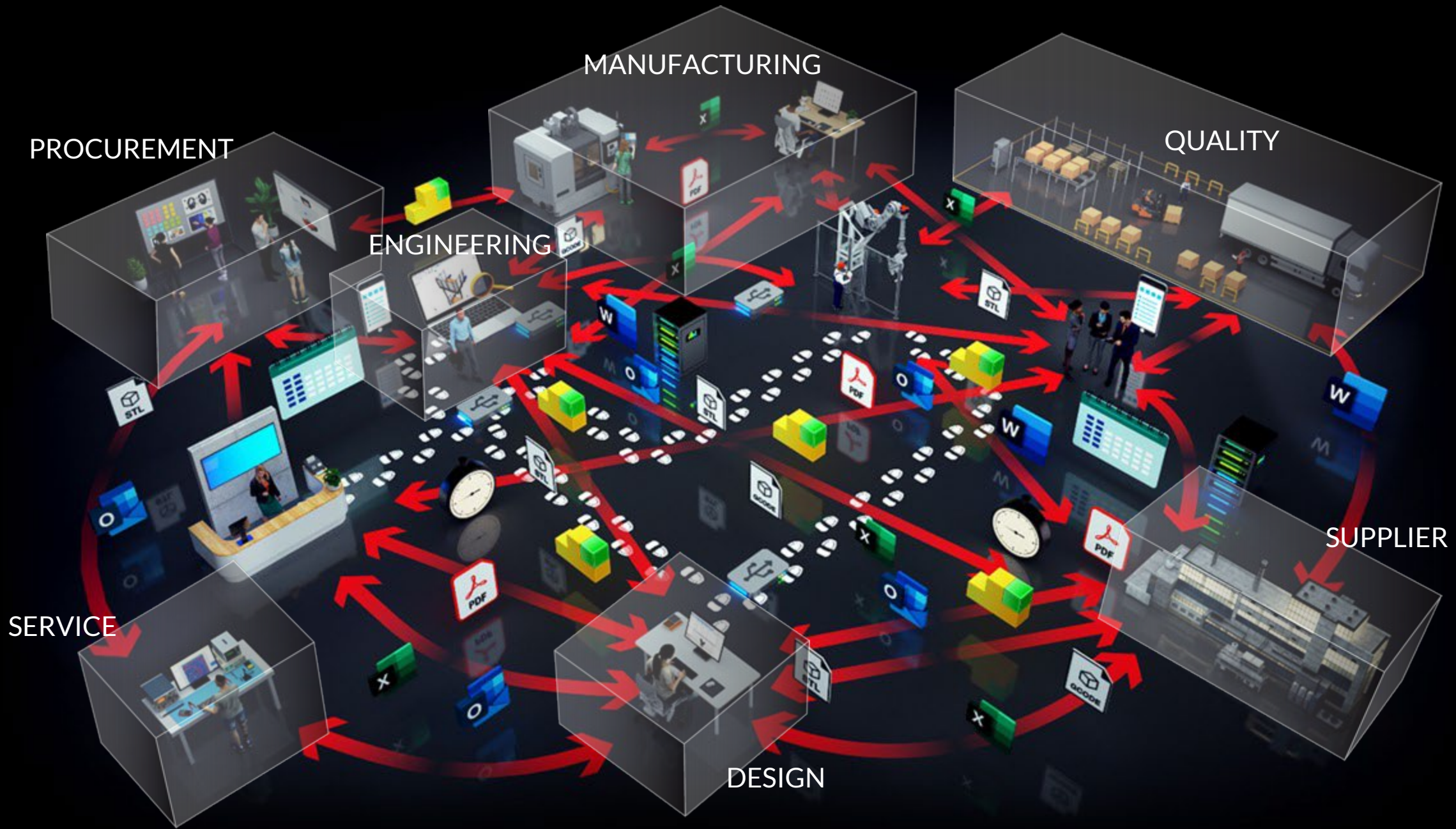

MANUFACTURING

QUALITY

PROCUREMENT

ENGINEERING

Data & Process Management



AUTODESK
Vault PLM



AUTODESK
Fusion 360 Manage
with Upchain



SUPPLIER

SERVICE

DESIGN

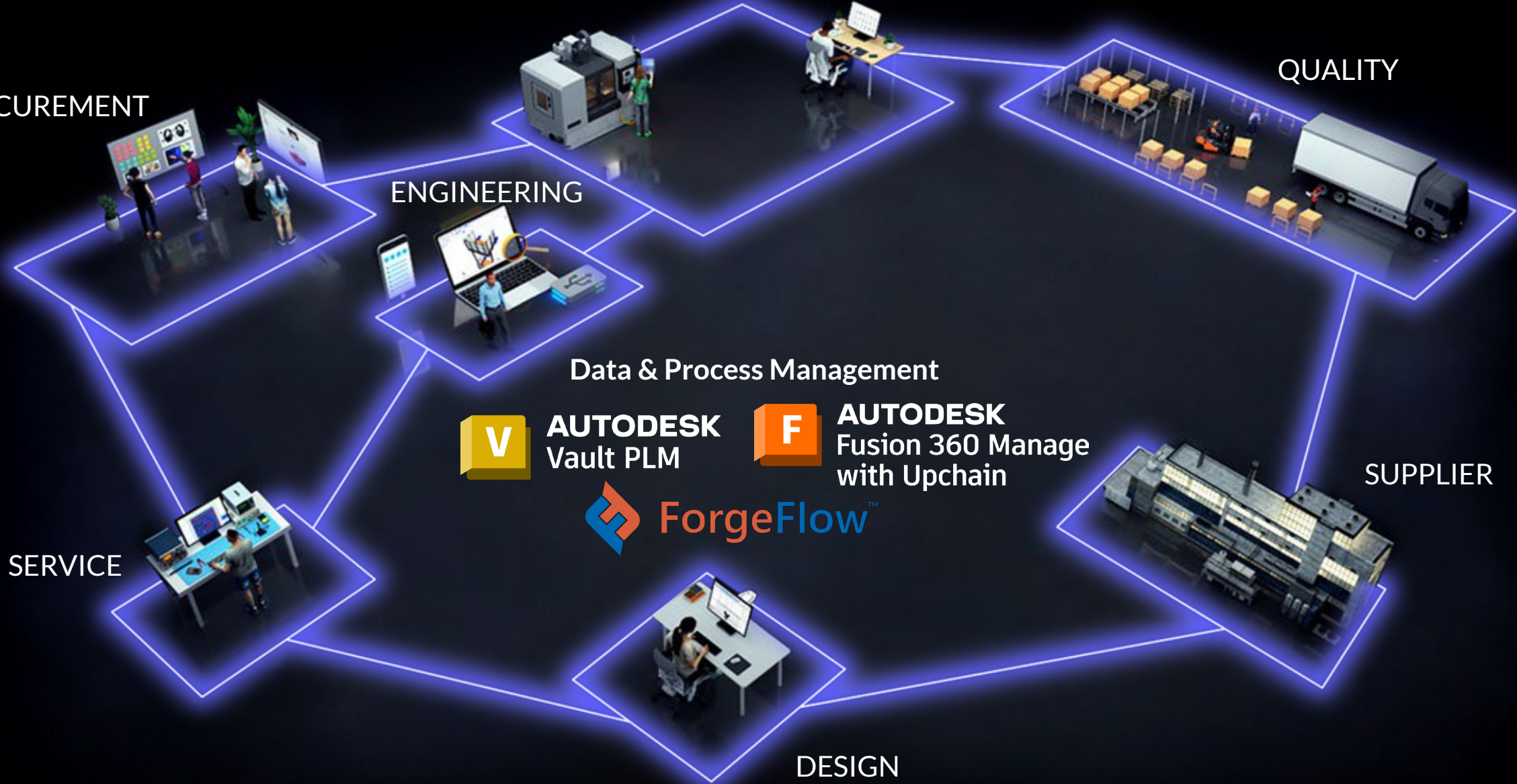

A woman wearing safety glasses is holding a green printed circuit board (PCB) with various electronic components. The background is a blurred workshop or laboratory setting. The text '45%' is overlaid in large white font.

45%

New products
delayed by one month



72%
Products fail to hit profit targets

One central source of truth

CAD

PDM / PLM

ERP / MRP

AutoCAD

Inventor

SWx

CREO

NX

Catia

Altium

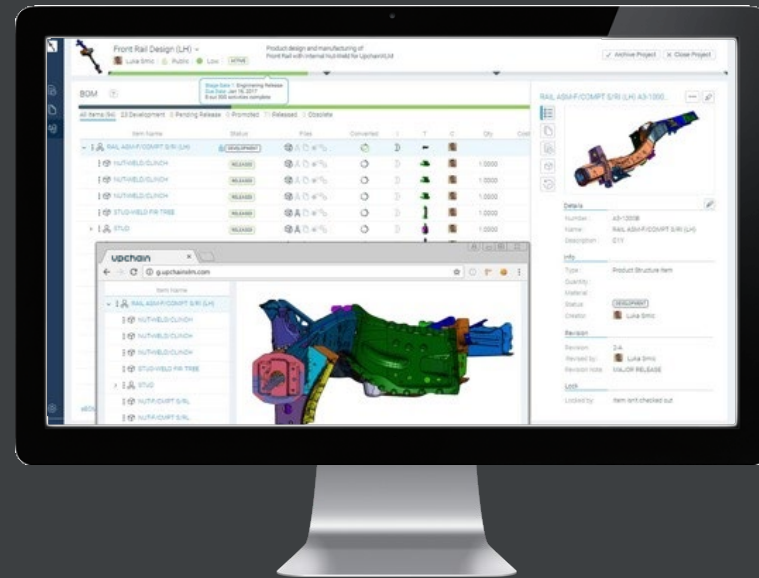

Integrated BOM

Service

CAD

Engineering

MFG

As built

As maintained

Data Management

The screenshot displays the Upchain web application interface. The browser address bar shows the URL: `live.upchain.net/?project=6318&page=4&previewItem=778089`. The application header includes the Upchain logo, navigation tabs for 'Projects', 'Team', and 'Create project', and a search bar. The main content area is titled '15539 - Change MGMT (10 ...)' and is managed by 'Edna Caulflower'. The interface is divided into several sections:

- BOM (Bill of Materials):** A tree view on the left shows the hierarchy of components, including 'Raspberry Pi 4 Model B' and its sub-components like '2.54 mm DUPONT MALE PIN HEADER, IO, 2X20, RPi4ModelB'.
- eBOM sBOM Table:** A central table lists components with columns for 'Item Name', 'Status', 'Files', 'Visualization', and 'Tasks'. All items are currently in 'DEVELOPMENT' status.
- eBOM Versions:** A section on the right shows the version history for the selected item.
- Details Panel:** A right-hand panel provides metadata for the selected item, including 'Item Number: AM-10928', 'Item Name: Raspberry Pi 4 Model B', 'Item type: Assembly', and 'Status: DEVELOPMENT'. It also lists the creator (Ryan Solomon) and other project details.

Visualize Comparisons

✕ BOM Compare

3D Compare Compared with: A-000099-AA-00-LOGITECH WEB CAMERA v000

Item Name	Status	Files	Visualization	Tasks	Creator	Qty	Thumbnail
✕ WEB CAMERA	DEVELOPMENT				MM		
+ ✕ CAMERA MOUNT PART 1-B	DEVELOPMENT				MM	1.0000	
+ ✕ CAMERA MOUNT PART 2-B	DEVELOPMENT				MM	1.0000	
+ ✕ CAMERA MOUNT PART 3-B	DEVELOPMENT				MM	1.0000	
✕ FRONT PANEL	RELEASED				MM	1.0000	
✕ CAMERA PROTECTOR	RELEASED				MM	1.0000	
⚠ ✕ EXTERNAL HOUSING	RELEASED				MM	1.0000	
+ ✕ 2K CAMERA	DEVELOPMENT				MM	1.0000	
- ✕ HD CAMERA	RELEASED				MM	1.0000	
- ✕ CAMERA MOUNT PART 3-A	RELEASED				MM	1.0000	
✕ CAMERA MOUNT PART 2-A	RELEASED				MM	1.0000	
✕ CAMERA MOUNT PART 1-A	RELEASED				MM	1.0000	

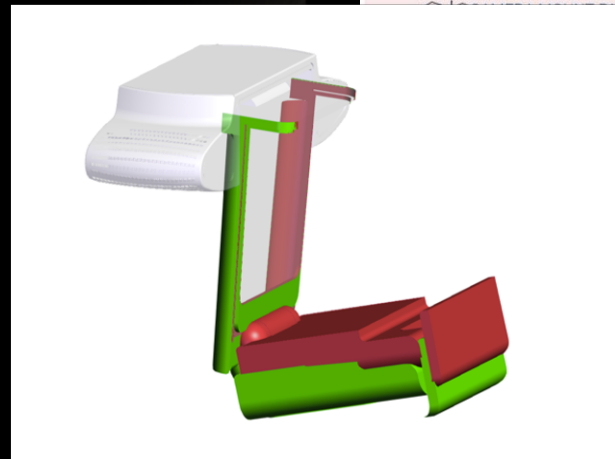

Imagine if....

Before



Lack of visibility



Disparate databases



Out of date PDFs

After



Right data to the right people at the right time



Central source of truth



Removes duplication of data

Optimize Your Processes

How do you currently handle your processes?

- Ad hoc – Manual
- Standardized by department
- Standardized company-wide
- Unsure
- Other (send us a note)

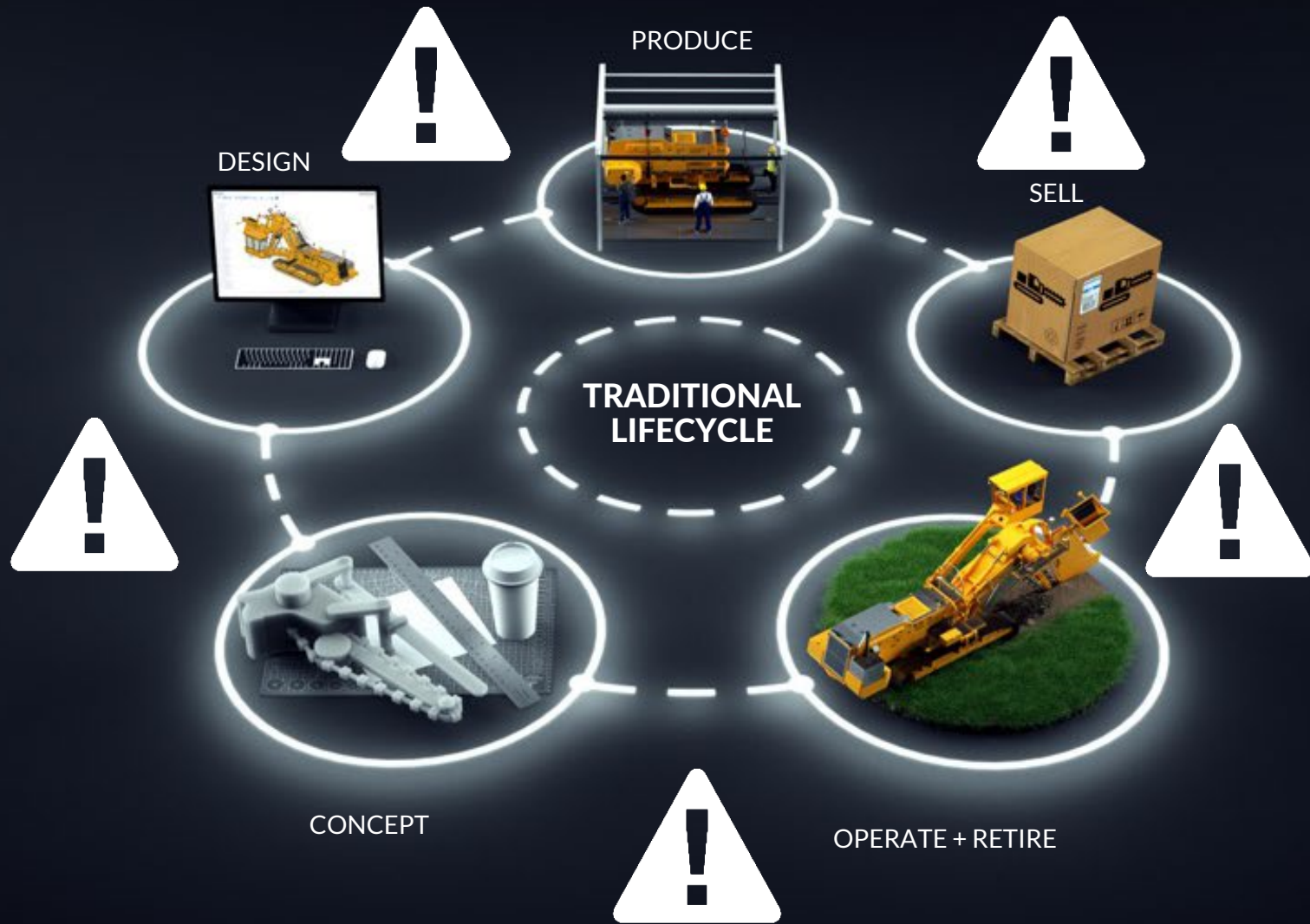



Enabling digital collaboration



New Product Introduction

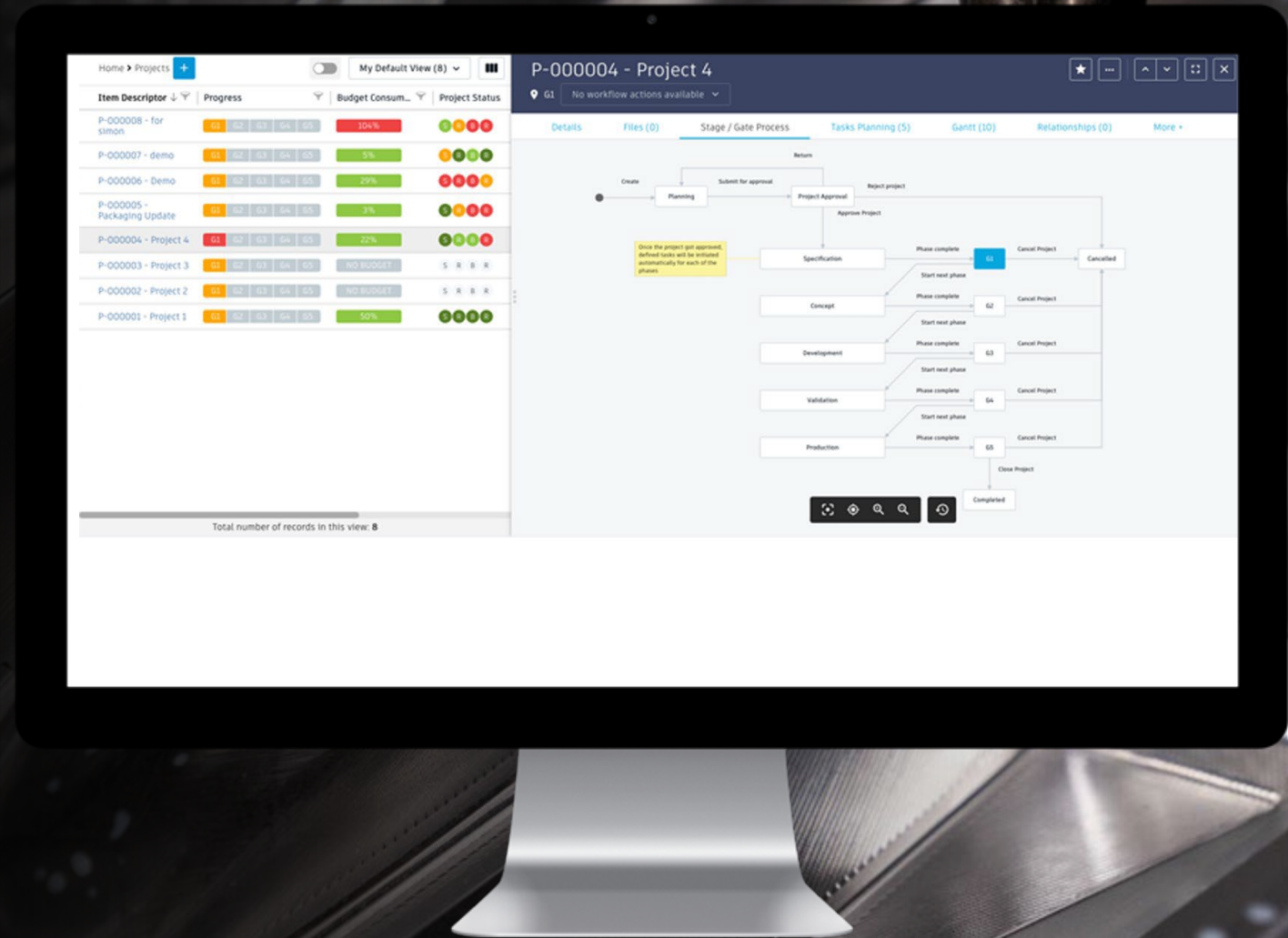

Bills of Materials Management

The screenshot displays a software interface for Bills of Materials Management. The main window title is "001-ASY-0001 - Top level printer in packaging [REV:9]". The interface includes a navigation bar with tabs for "Details", "Bill of Materials (15)", "Where Used (1)", "Related Changes (1)", "Attachments (0)", and "Change Log". Below the navigation bar, there are buttons for "Edit", "Add", and "Remove". The main content area shows a table of components with columns for "#", "Descriptor", "Revision", "Lifecycle", "Quantity", "Units", "Control Drawing Num...", and "Cont...". A dropdown menu is open on the right side, showing options like "Costing", "Export", "Supply Chain", "Environmental Compliance", "Export BoM Only", "Do Not Buy List", "Purchasing View", "mBOM", and "Procurement".

#	Descriptor	Revision	Lifecycle	Quantity	Units	Control Drawing Num...	Cont...
0.0	001-ASY-0001 - Top level printer in packaging [REV:9]	9	Production	0.0	-	-	-
1.1	001-DOC-0001 - Packaging Assembly Document [REV:0]	0	Production	0.0	ea	001-DOC-0001	-
1.3	001-PKG-0002 - Packing Tape [REV:1]	1	Production	6.0	ft	001-DOC-0075	-
1.9	001-PKG-0008 - Printer Bag [REV:1]	1	Production	1.0	ea	001-DOC-0080	-
1.13	001-PKG-0012 - Desiccant [REV:0]	0	Production	3.0	ea	-	-
1.14	001-PKG-0013 - Rotating Window Shipping Tape [REV:0]	2	Production	1.0	ft	-	-
1.16	001-DOC-0116 - Serial Number Label [REV:0]	0	Production	1.0	ea	-	-
1.19	001-ASY-0002 - Resin Tray Assembly [REV:12]	12	Production	4.0	ea	001-DOC-0002	3
1.20	001-ASY-0038 - Build Head Assembly [REV:1]	1	Production	2.0	ea	-	-
1.21	001-ELC-0056 - Power Supply [REV:0]	0	Production	1.0	ea	-	-
1.23	001-ELC-0058 - USB Cable [REV:0]	0	Production	1.0	ea	-	-
1.24	001-ASY-0004 - Assembled Printer [REV:12]	12	Production	1.0	ea	001-DOC-0086	-
1.25	001-DOC-0148 - Stocking Label [REV:1]	1	Production	1.0	ea	001-DOC-0148	-
1.26	001-ASY-0051 - Packaging Assembly [REV:2]	2	Production	1.0	ea	-	-
1.27	001-DOC-0147 - Branding & Certification Label [REV:2]	2	Production	2.0	ea	-	-

Change Management

The screenshot displays a software interface for Change Management. On the left, a list of change orders is shown with columns for Item Descriptor, Progress, and Flag. The right side shows a detailed view for change order CO-000003 - Seal is broken, including a workflow diagram and various tabs like Details, Attachments, and Approval Workflow.

Item Descriptor	Progress	Flag
CO-000016 - LK1	NEW PERFORM CCB REL	...
CO-000005 - Product Update	NEW PERFORM CCB REL	...
CO-000010 - rel	NEW PERFORM CCB REL	...
CO-000014 - Änderung	NEW PERFORM CCB REL	...
CO-000015 - Freigabe	NEW PERFORM CCB REL	...
CO-000012 - CR2	NEW PERFORM CCB REL	...
CO-000009 - Change material supplier	NEW PERFORM CCB REL	...
CO-000011 - update	NEW PERFORM CCB REL	...
CO-000001 - Strengthen fixture	NEW PERFORM CCB REL	...
CO-000007 - Battery Housing Update	NEW PERFORM CCB REL	...
CO-000004 - Initial Release	NEW PERFORM CCB REL	...
CO-000013 - Freigabeprozess	NEW PERFORM CCB REL	...
CO-000006 - New Engine Module	NEW PERFORM CCB REL	...
CO-000008 - Noisy Bearing on Motor	NEW PERFORM CCB REL	...
CO-000003 - Seal is broken	NEW PERFORM CCB REL	...
CO-000002 - Water leaks	NEW PERFORM CCB REL	...

CO-000003 - Seal is broken

Locked | Implemented | No workflow actions available | Revert workflow action

Details | Attachments (0) | Affected Items (5) | Task Planning (0) | Approval Workflow | More +

The workflow diagram shows the following steps: Start -> Preparation -> Initiate Tasks -> Perform Change -> Tasks Completed -> Results Review -> Submit to CCB -> Change Control Board Review -> Approve -> Final Approval -> Released -> All Confirmed -> Implemented. Alternative paths include: Preparation -> Cancel change Order -> Cancelled; Preparation -> Submit to CCB (Fast Track) -> Change Control Board Review; Change Control Board Review -> Return / Reject -> Initiate Additional Tasks -> Perform Change; Change Control Board Review -> Request External Review -> External Review -> External Approval Received -> Final Approval; Change Control Board Review -> External Rejection Received -> External Review -> External Approval Received -> Final Approval.

16 out of 16 total records in this view being displayed.

Quality Management

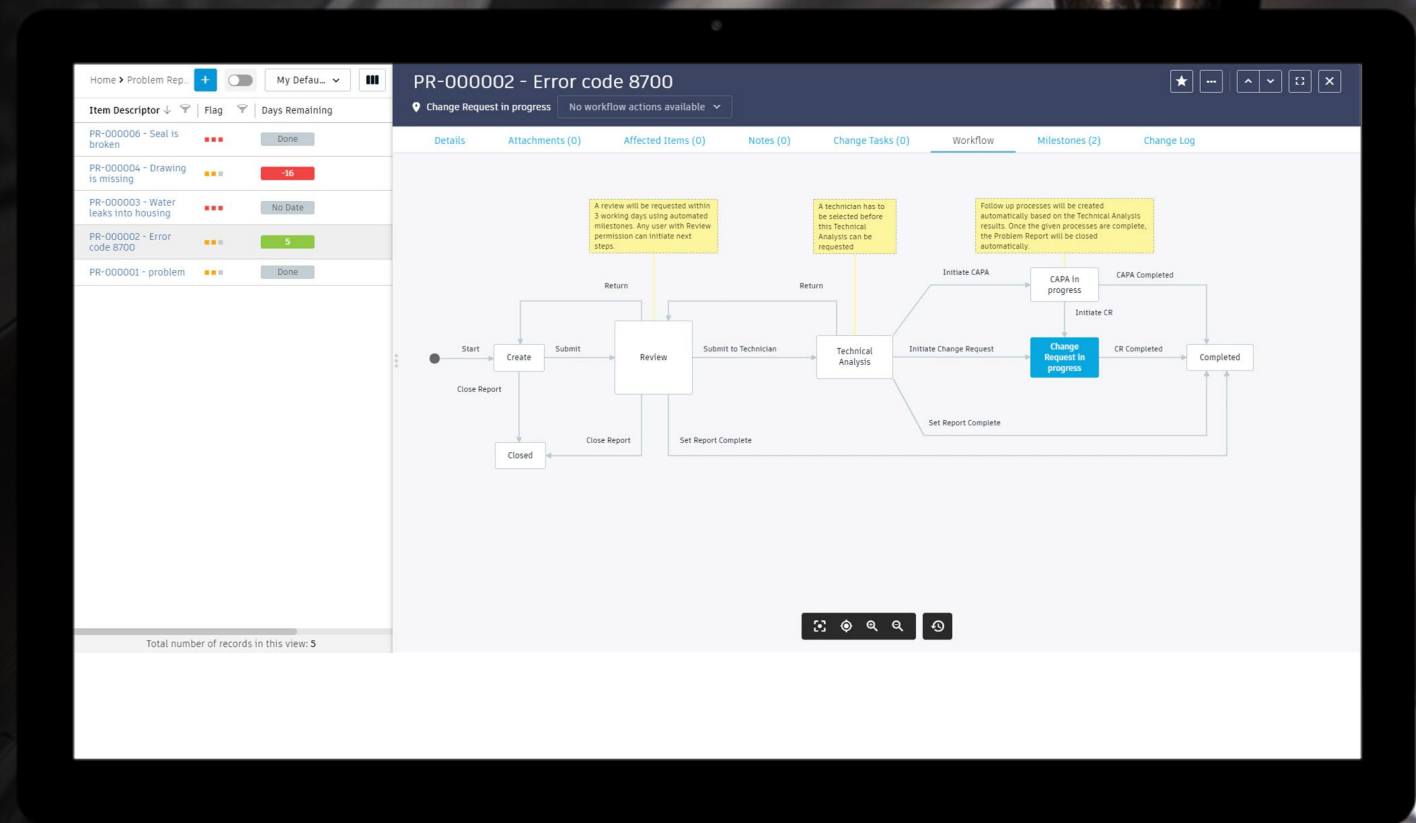

Supplier Management

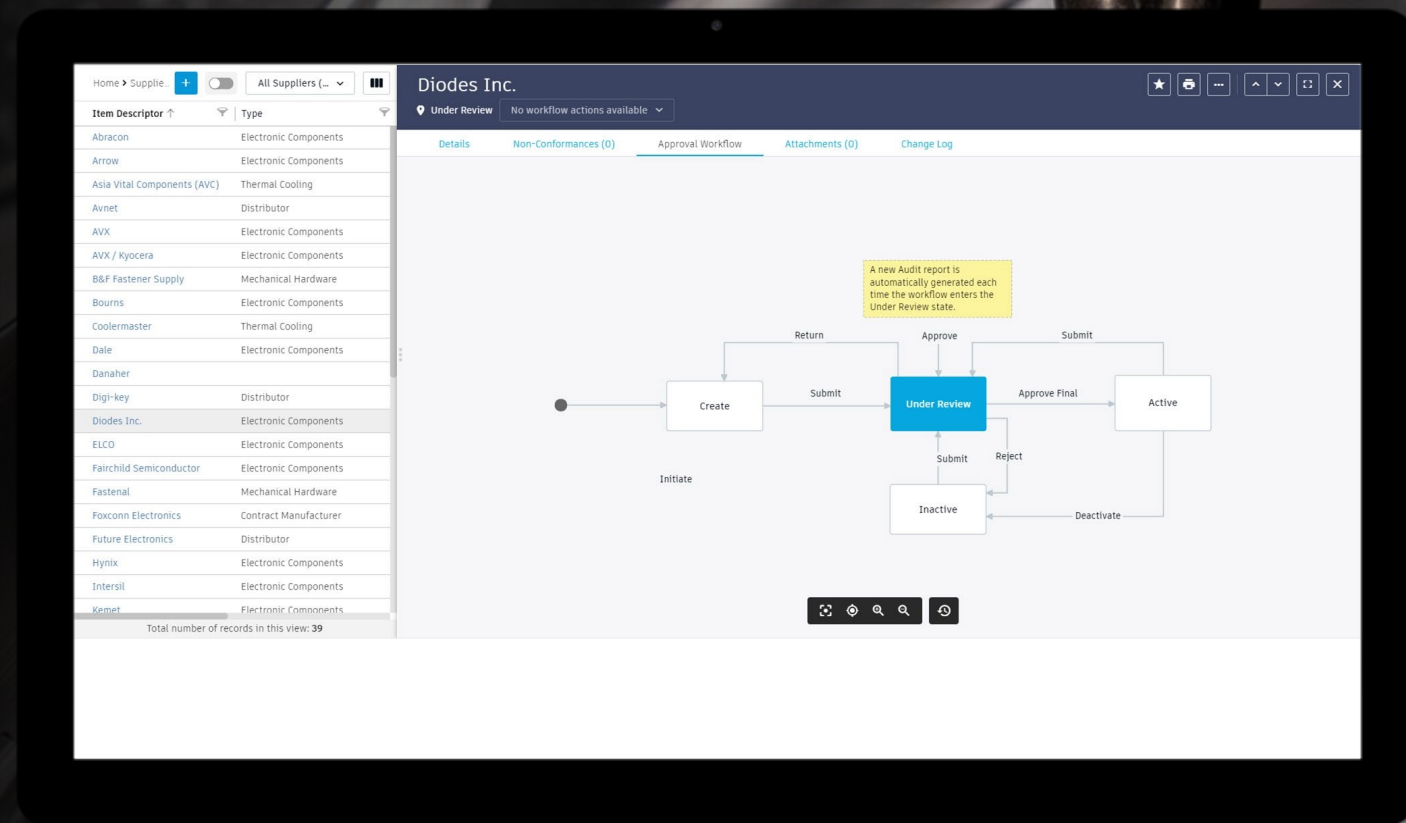

Fusion Connected Product Development Platform

Platform



Framework

Standardized

Interoperable

Configurable

Extensible

Foundations

Engineering Management

Product Management

Quality Management

Supply Chain Management

Project Management

Digital Asset Management

Scale PSO's

- Product Catalog
- NPI
- NPD
- PID - (Inspection Manuals)
- Product Certifications
- Product Reviews
- Product Features
- Product Images
- Product Numbers
- Product Configurator
- Product Change Notification
- Product Analysis
- Product Pricing
- Price Adjustments
- Pricing Rules
- SEO and Search
- Users and Roles
- Classification Library
- Projects and Tasks
- Items and BOMs
- EBOM
- MBOM
- Raw Materials
- Manufacturing Part Numbers
- Engineering Requirements Documents
- Manufacturer Change Order
- Rapid Innovation Release
- Product Change Notification
- FMEA
- Users and Roles
- Classification Library
- Projects and Tasks
- Ideas
- Requirements
- Personas
- Knowledge Base
- Terms and Definitions
- Work Instructions
- Checklists
- Collections
- Training Courses
- Personal Notebook
- Policies and Procedures
- Category Management
- Users and Roles
- Classification Library
- Projects and Tasks
- Quality Documents
- Supplier Documents
- Controlled Documents
- Requirement Documents
- FAI Documents
- Users and Roles
- Classification Library
- Projects and Tasks
- Customers
- Sales Quotes
- Sales Orders
- Purchase Orders
- Product Analysis
- Product Pricing
- Price Adjustments
- Pricing Rules
- SEO and Search
- Sales Channel
- Users and Roles
- Classification Library
- Projects and Tasks
- APQP
- PPAP
- Part Submission Warrant
- CAPA
- Audits
- FMEA
- Quality Control Plans
- Non Conformance Reports
- Reason Codes
- QA Sampling Plans
- Deviation and Waiver Requests



Fusion Connected Product Development Platform

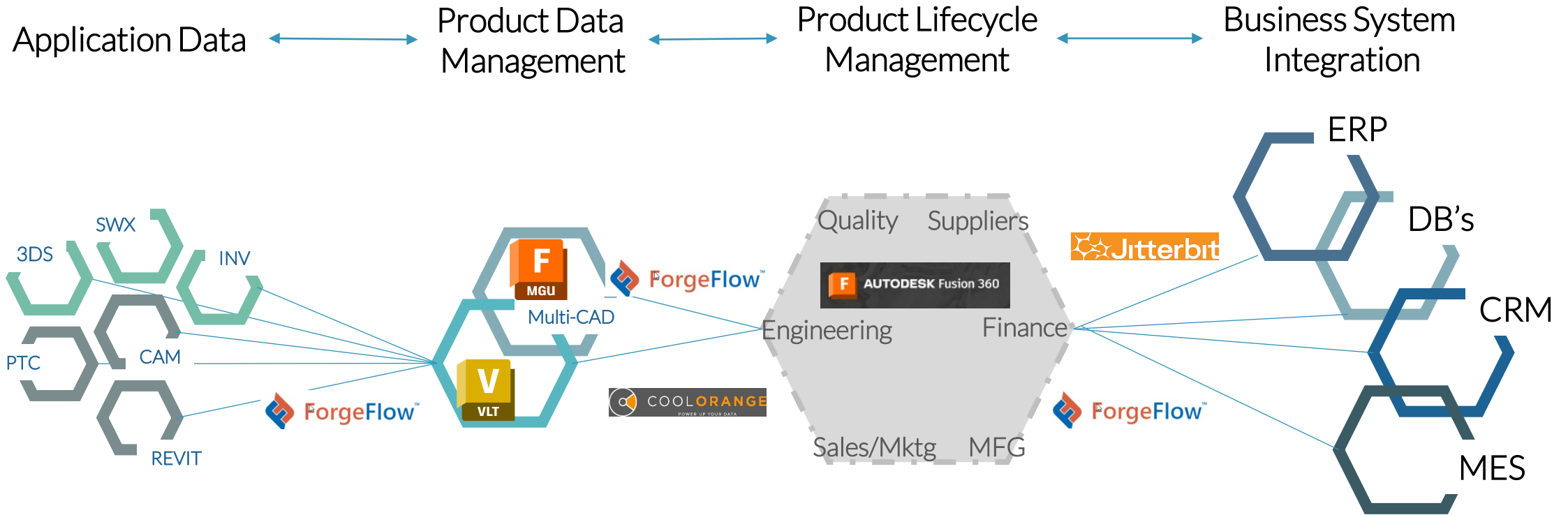

Imagine if...

Before



Emails with screenshots



Manual, disconnected processes



Manual exports

After



Markups captured and communicated



Automated workflows



Singular platform for viewing

Centralize Your Stakeholders

How many companies communicate with project stakeholders

- Email
- Messenger (teams, slack, google chat, etc)
- Phone
- Comments/markup on shared docs
- Video calls/meetings (zoom, teams, etc)
- In person (meetings/walking to their desk)
- Other (send us a note)



Suppliers



Customers



**Outsourced
Engineering**



Partners

Connect everyone, everywhere, all the time

Anytime, anywhere access with a user experience your people will love



Web application



Cloud-based



Configurable tenants



Software as a service



Trusted Autodesk framework

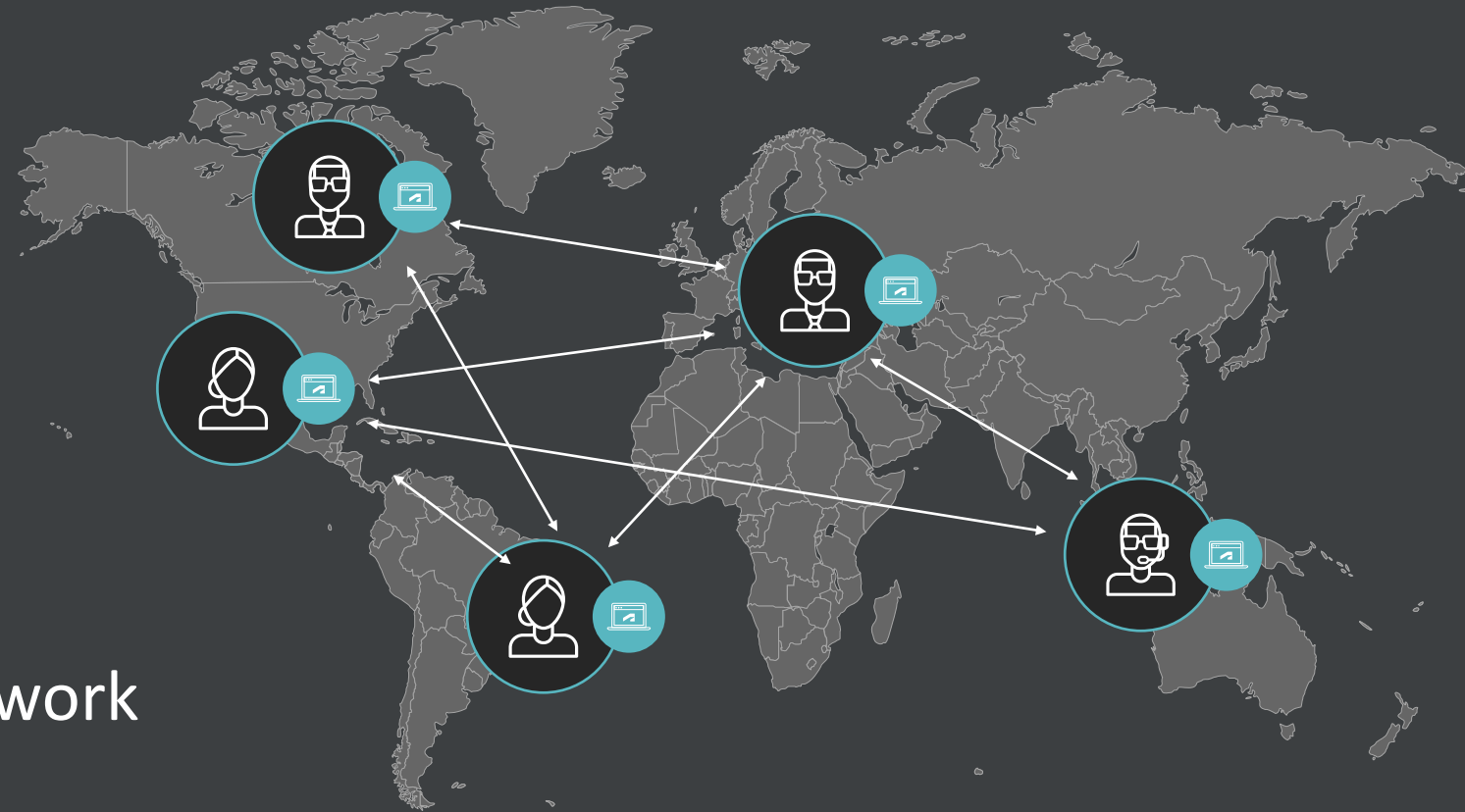

CAD data for non-CAD users

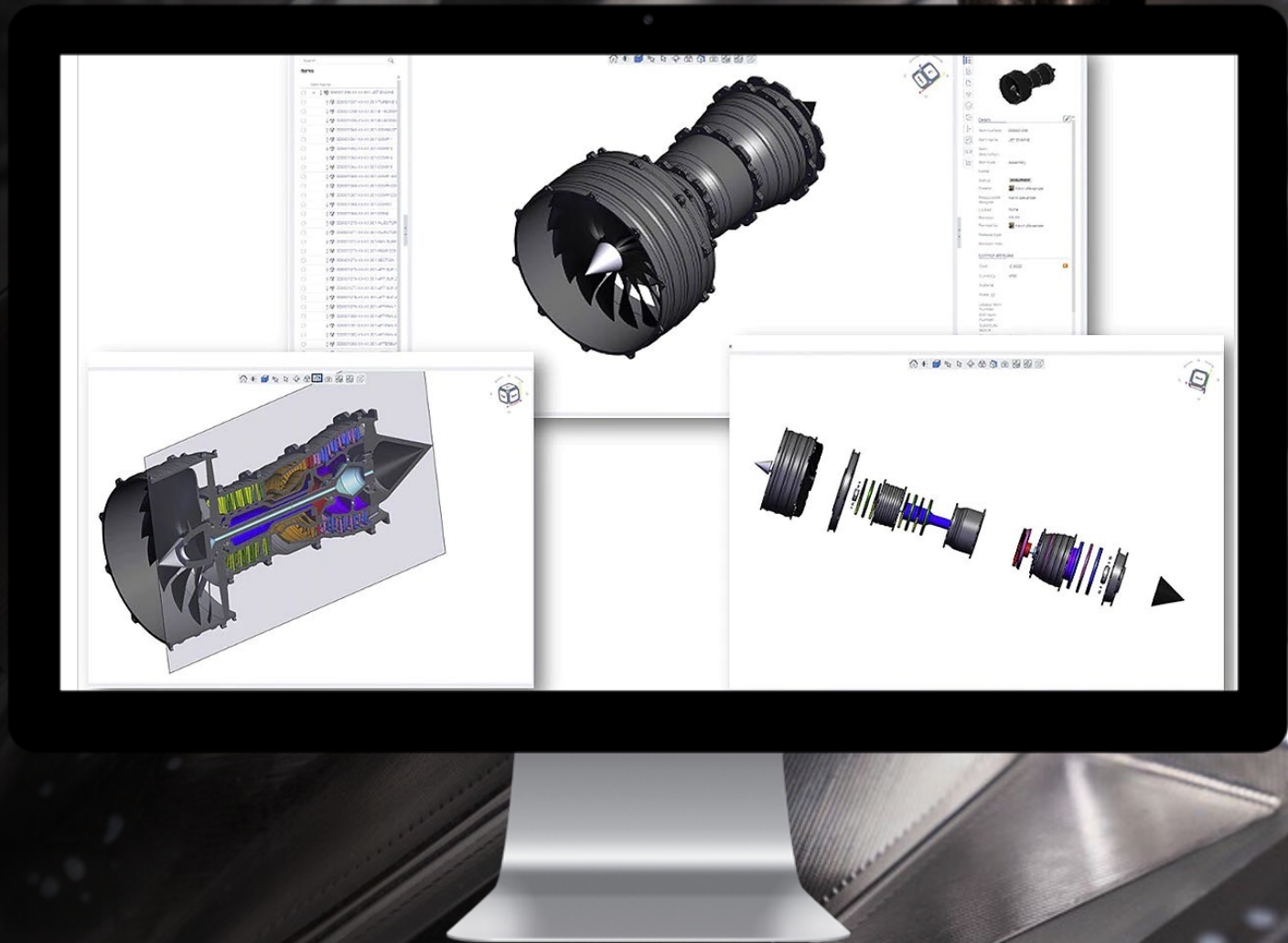

Design collaboration and review

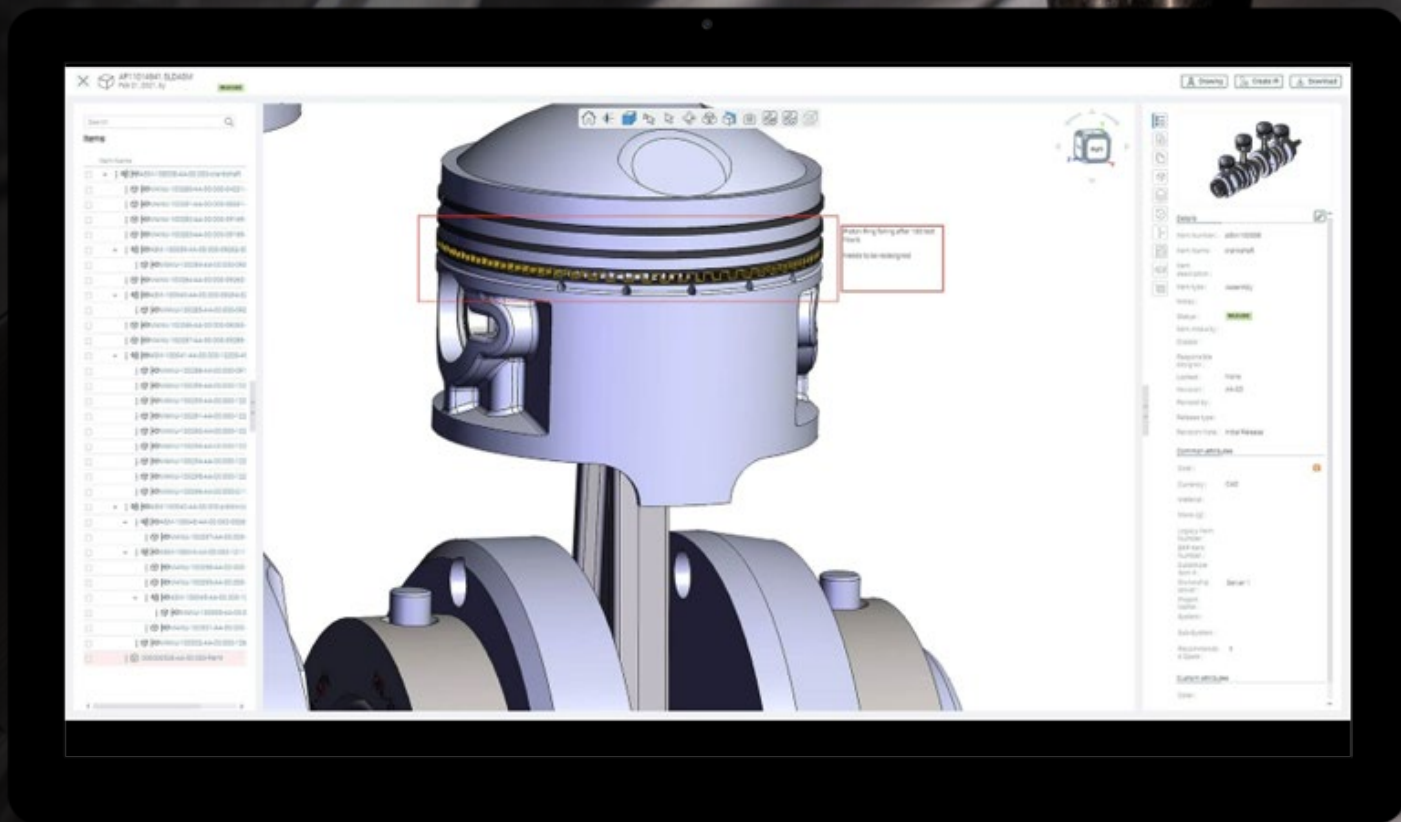

Supplier Collaboration

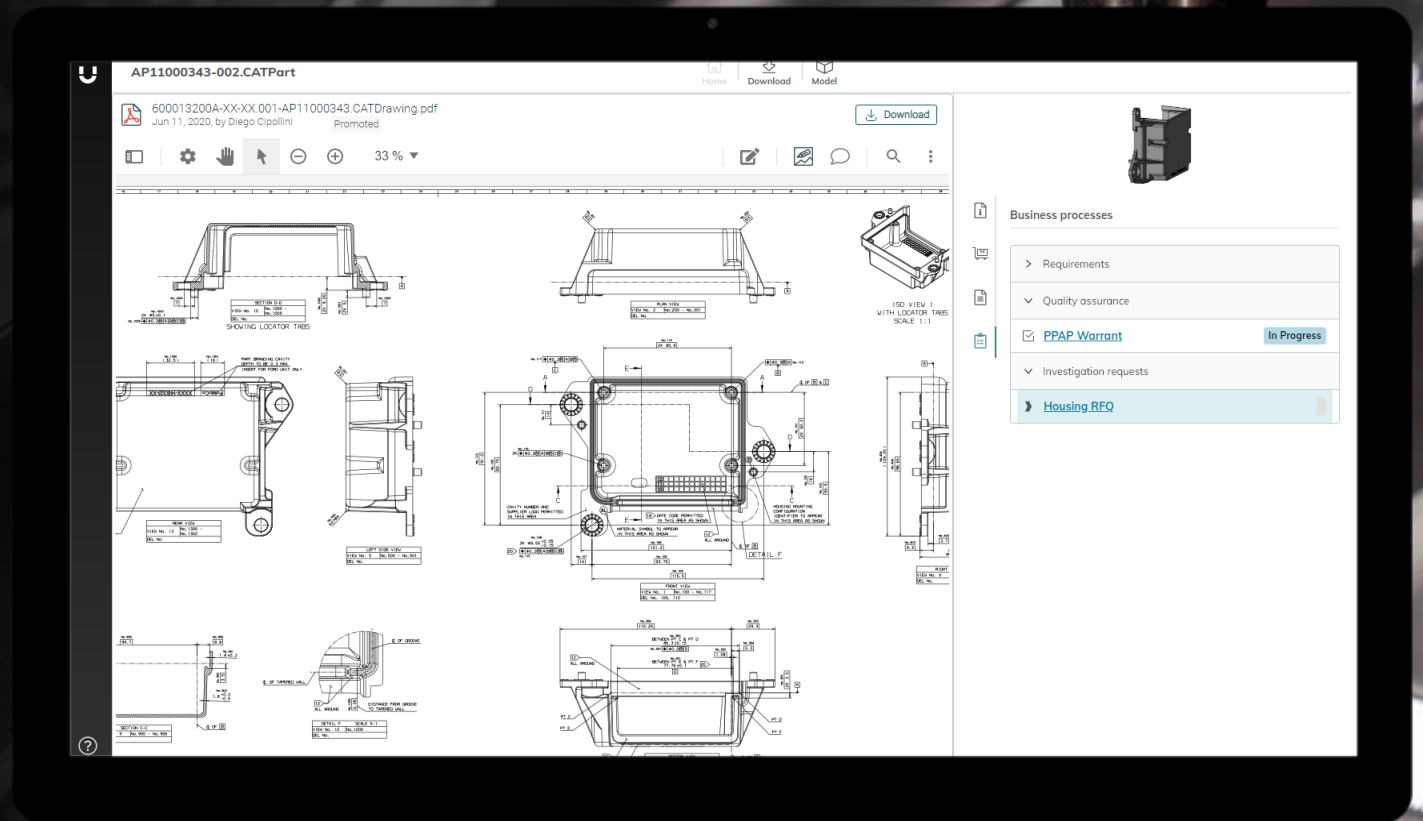

Imagine if....

Before



Emails to request supplier information



Un-secured data transfer



Meetings, calls

After



Standardized template for RFQs



Secure and granular access to data



Timely feedback loop from outside stakeholders

Q&A



Call to Action

- Discuss your Process and Data needs
 - Ben.Banford@teamd3.com
- Watch AU 2022 Classes
 - [Vault: Marvin Windows](#)
 - [PLM: Starting Simple](#)
 - [Power Up Your PLM with ForgeFlow](#)
 - [All Team D3 Classes at AU 2022 Playlist](#)
- Read the ForgeFlow Blog
 - [ForgeFlow Blog \(teamd3.com\)](#)
- Find our listing in Customer Success Hub
 - <https://customersuccess.autodesk.com/partners/1131>
- Get Started Easily with Our Foundation Packs
 - [Packaged Service Offerings | Solutions | D3 Technologies](#)



A COMMONLY-OWNED COALITION OF BRANDS



www.TeamD3.com



877.731.7171



Info@TeamD3.com